



www.santos.fr

**SILENT SHOP
COFFEE GRINDER
WITH BAG HOLDER # 43**



Internationally patented models





THE TRADITIONAL SHOP COFFEE GRINDER SINCE 1956

Sturdy and powerful shop coffee grinder with bag holder.

Easy to use and efficient, the shop coffee grinder # 43 will give you a high quality grinding. Ideal for shops, supermarket, coffee roasters, bakeries...

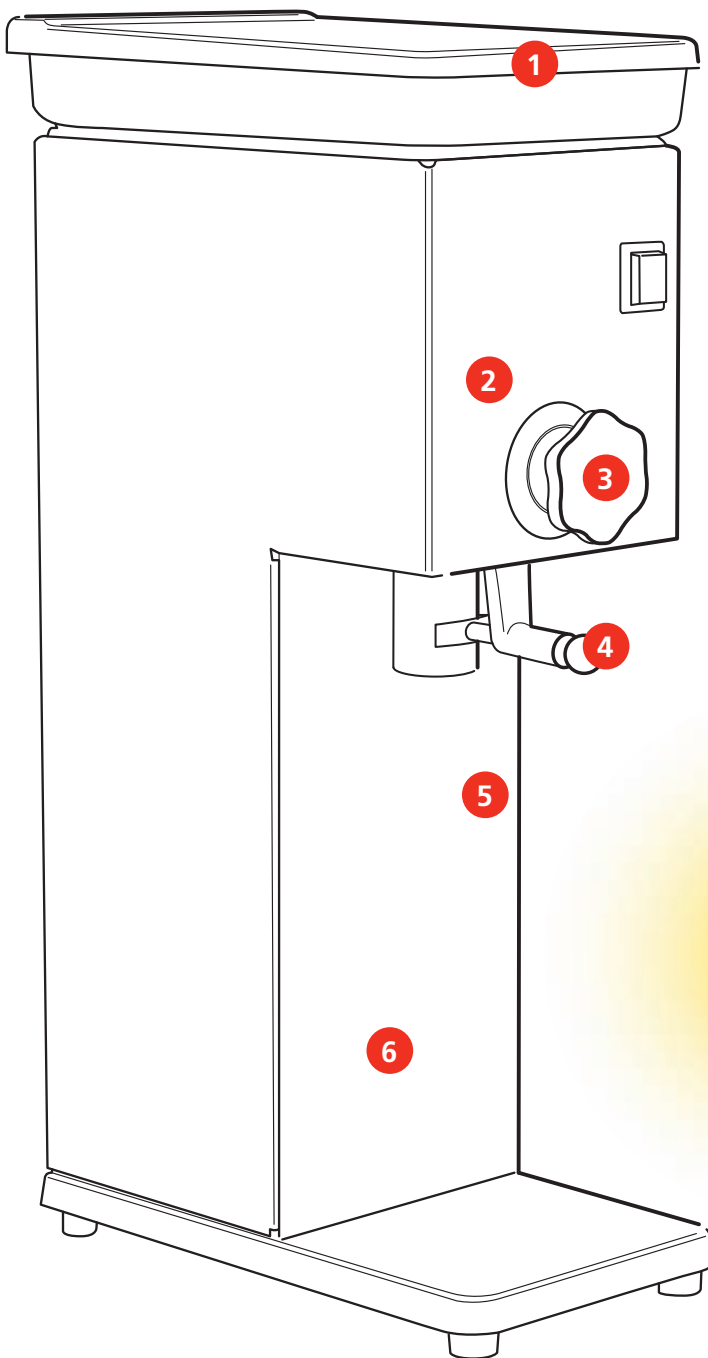

- 1. 1.7 kg (3.8lbs) hopper
- 2. Ø 63.5mm (2,5") grinding discs:
high resistance, long lasting
Designed and manufactured by Santos for a high quality grinding
- 3. **Precision grinding,**
from very fine to coarse. Easy to adjust.
- 4. **Bag holder accepting bags from 250 g to 1kg**
(1/2 pounds to 2 pounds) Maximum bag height: 360 mm
- 5. Stainless steel body
- 6. **Powerful asynchronous motor**
5-year warranty



Output of the coffee grinder # 43

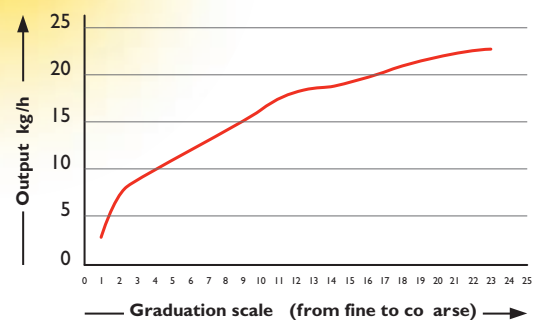

GRINDER WITH BAG HOLDER # 43



COFFEE GRINDERS: SANTOS KNOW-HOW

www.santos.fr

Santos, 60 years experience

- Since 1954, we manufacture our own grinding discs for better results
- Santos is the leader in “Silent” coffee grinders for 15 years
- Constant and fine grinding, constant portion dispensed
- No “burn coffee” effect while grinding, no electrostatic coffee phenomenon
- Easy to adjust (grinding and dosing) and to maintain (changing the grinding discs is very easy)



TECHNICAL SPECIFICATIONS



Motor

Single phase: 110-120 V – 50/60 Hz – 650 W – CE
220-240 V – 50/60 Hz – 600 W – CE

Speed: 1500 rpm (50 Hz)
1800 rpm (60 Hz)



Weight

Net: 20 Kg (44.09 lbs)
Shipping: 22 Kg (48.5 lbs)

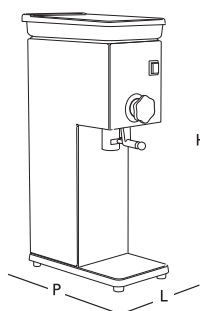

APPLIANCE

L: 190 mm (7.5")
P: 335 mm (14")
H: 690 mm (27")

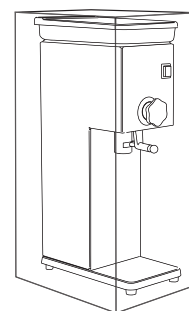

SHIPPING BOX

L: 280 mm (11")
P: 390 mm (15.3")
H: 760 mm (30")

SAFETY, STANDARDS, HYGIENE

In accordance with the following regulations

Machinery directive 2006/42/EC
Electromagnetic compatibility 2004/108/EC
“Low voltage” Directive 2006/95/EC
Regulation 1935/2004/EC (contact with food)
RoHS directive 2002/95/EC

Harmonized European Standards
NF EN ISO 12100 - 1 and 2: 2004
NF EN 60204-1: 2006

CE European standards

Thermal Safety

Motor protected by internal thermal detector

Acoustic Safety

Very silent and powerful asynchronous motor

Hygiene

All removable parts can be put in a dishwasher or easily cleaned with hot soapy water.

PRODUCT: 2-YEAR WARRANTY – MOTOR: 5-YEAR WARRANTY



SILENT SHOP COFFEE GRINDER WITH BAG HOLDER # 43

www.santos.fr

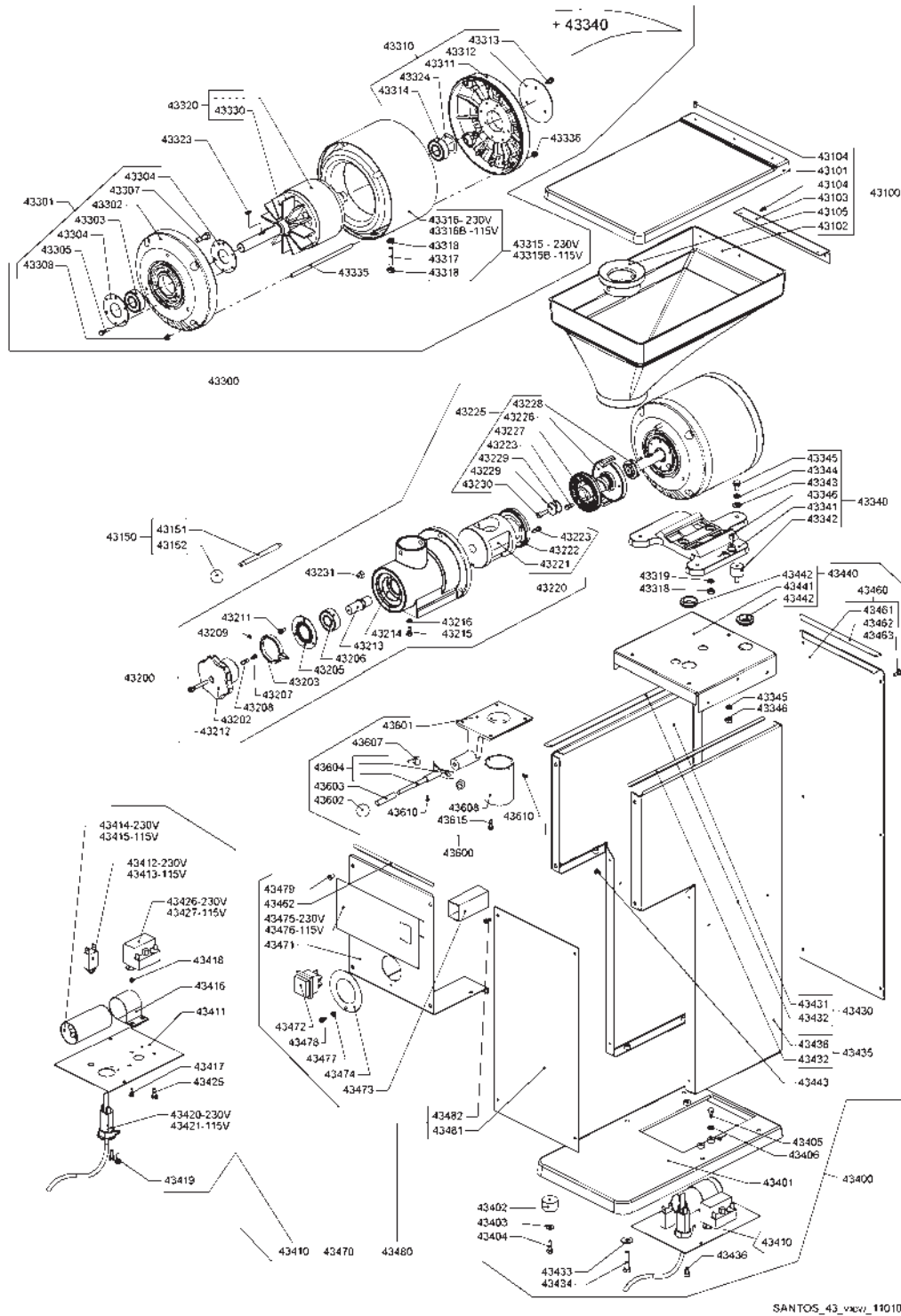

SANTOS_43_vskw_110102

140-150 AV ROGER SALENGRO – 69120 – VAULX ENVELIN – LYON – FRANCE – TEL. +33 472 37 35 29 – FAX. +33 478 26 58 21
Website: www.santos.fr – **E-mail:** santos@santos.fr